

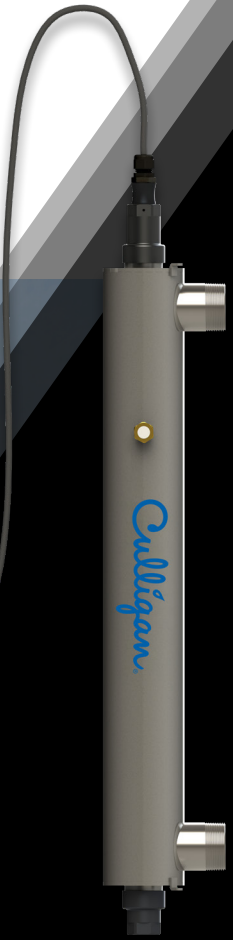





## Operation & Installation Instructions



# Table of Contents

Product Matrix.....	1
Safety Considerations .....	2
Before You Begin.....	3
Water Quality Parameters.....	3
Assembly.....	4
System Sizing.....	5
Installation Location .....	5
Considerations Before Installation .....	6
Installation.....	7
System Disinfection.....	9
Cleaning the quartz sleeve.....	9
Cleaning the UV sensor .....	10
Operation - Control Panel .....	11
Operation - 3-Position Switch.....	11
Operation - Power-up .....	12
Operation - UV Intensity.....	12
Operation - Major & Minor Alarm Set Points .....	13
Operation - Lamp Countdown .....	13
Operation - Lamp Countdown Reset.....	13
System Troubleshooting.....	14
Expansion Options .....	15
Specifications.....	16-17
Warranty Registration .....	18
Limited Warranty Statement .....	19

# Product Matrix

SYSTEM	 <b>"Normal" Disinfection</b> 30 mJ/cm <sup>2</sup> @ 95% UVT	 <b>LOW UVT Disinfection</b> 30 mJ/cm <sup>2</sup> @ 50% UVT	 <b>TOC Disinfection</b> 150 mJ/cm <sup>2</sup> @ 95% UVT
1-lamp "35" series	CUVR5-35X	CUVR5-35X	CUVR5-35X-TOC
	CUVR6-35X	CUVR6-35X-50	CUVR6-35X-TOC
1-lamp "55" series	CUVR5-55X	CUVR5-55X	CUVR5-55X-TOC
	CUVR6-55X	CUVR6-55X-50	CUVR6-55X-TOC
1-lamp "85" series	CUVR5-85X	CUVR5-85X	CUVR5-85X-TOC
	CUVR6-85X	CUVR6-85X-50	CUVR6-85X-TOC
2-lamp "110" series	CUVR5-110X	CUVR5-110X	CUVR5-110X-TOC
	CUVR6-110X	CUVR6-110X-50	CUVR6-110X-TOC
2-lamp "140" series	CUVR5-140X	CUVR5-140X	CUVR5-140X-TOC
	CUVR6-140X	CUVR6-140X-50	CUVR6-140X-TOC
2-lamp "175" series	CUVR5-175X	CUVR5-175X	CUVR5-175X-TOC
	CUVR6-175X	CUVR6-175X-50	CUVR6-175X-TOC
<p><b>Replace "X" with "1" for North American 120V</b>  <b>Replace "X" with "5" for North American, NEMA 6-15, 3 prong for all 230V</b></p>			

# Safety Considerations

It is important that care is taken when operating and/or maintaining your system.

## Please read the instructions

- **Energy given off by the UV lamp is harmful to your eyes and skin. NEVER look directly at an illuminated UV lamp without adequate eye protection and always protect your skin from direct exposure to the UV light.**
- WARNING: During periods of reduced water flow, reactor may be hot.
- WARNING: Do not operate the UV-C emitter when it is removed from the appliance enclosure.
- The appliance is to be supplied through a residual current device (RCD) having a rated residual operating current not exceeding 30 mA.
- This appliance contains a UV-C emitter.
- Unintended use of the appliance or damage to the housing may result in the escape of dangerous UV-C radiation. UV-C radiation may, even in little doses, cause harm to the eyes and skin.
- The appliance must be disconnected from the supply before replacing the UV-C emitter.
- The appliance is intended to be permanently connected to the water mains and not connected by a hose-set.
- Maximum working voltage of built-in UV driver U-OUT=240V
- If the power supply cord is damaged, it must be replaced by the manufacturer, its service agent or similarly qualified persons in order to avoid a hazard.
- Before servicing this equipment, disconnect the power cord from the electrical outlet.
- For complete disinfection, use ONLY genuine replacement parts.
- Do not operate the unit if it has any damaged or missing components.
- To avoid possible electrical shock, use only with a properly grounded electrical outlet.
- Never perform any maintenance to the system unless you are comfortable in doing so. Contact the manufacturer for service instructions if required.
- Do not use this system for any purpose other than what it was intended for. Misuse of this system could potentially cause harm to the user or others.
- Your system is intended to be installed indoors and away from leaking plumbing. DO NOT plug the unit in if the system or any of the electrical components are wet.
- The disinfection system should be directly installed into a ground fault circuit interrupter (GFCI). Please note that for 230 volt CULLIGAN commercial products, special High-current GFCI's (GFI's) are required. These special GFCI's can easily be obtained through an electrical supply house, or are readily available from a local spa/hot tub supply store as they are commonly used in these applications.

- The appliance is not to be used by persons (including children) with reduced physical, sensory or mental capabilities, or lack of experience and knowledge, unless they have been given supervision or instruction.
- Children should be supervised so that they do not to play with the appliance.
- We recommend that a licensed plumber or certified technician install the system.

**THIS PRODUCT IS NOT TO BE USED FOR GENERAL LIGHTING / ILLUMINATION.**

## Before you begin

### Water Quality Parameters

UV disinfection is only effective if the UV light can pass through the water it needs to treat. This means that the quality of your water is very important in order to ensure complete disinfection.

Treated water should be tested for at the least the parameters listed below. If the water exceeds the listed parameters CULLIGAN strongly recommends that appropriate pretreatment equipment be installed (equipment required will depend on parameters being treated):

---

**Hardness:** <7 gpg (120 mg/L) – if hardness level is 7 gpg or slightly below the quartz sleeve must be cleaned periodically in order to ensure efficient UV penetration; if above the water must be softened.

**Iron (Fe):** <0.3 ppm (0.3 mg/L)

**Manganese (Mn):** <0.05 ppm (0.05 mg/L)

**Turbidity:** < 1 NTU

**Tannins (organics):** <0.1 ppm (0.1 mg/L)

**UVT (transmittance):** >85% (Please contact CULLIGAN if water has a UVT that is less than 80% for pre-treatment recommendations)

---

You can have your water tested at a private analytical laboratory or by your local dealer. It is always recommended to install pre-filtration of at least 5 microns prior to a CULLIGAN UV disinfection system.

### Installation Tools

- Pipe cutter, hacksaw or other specialized tools required to cut into your existing plumbing (e.g. if you have PEX piping)
- Soldering tools (torch, flux, emery cloth and solder)
- Wrench (for tightening fittings)
- Inlet/outlet connections
- Teflon™ tape

# Assembly

Unpack the system and ensure all the components are included with the system. Your system is shipped with the following components:

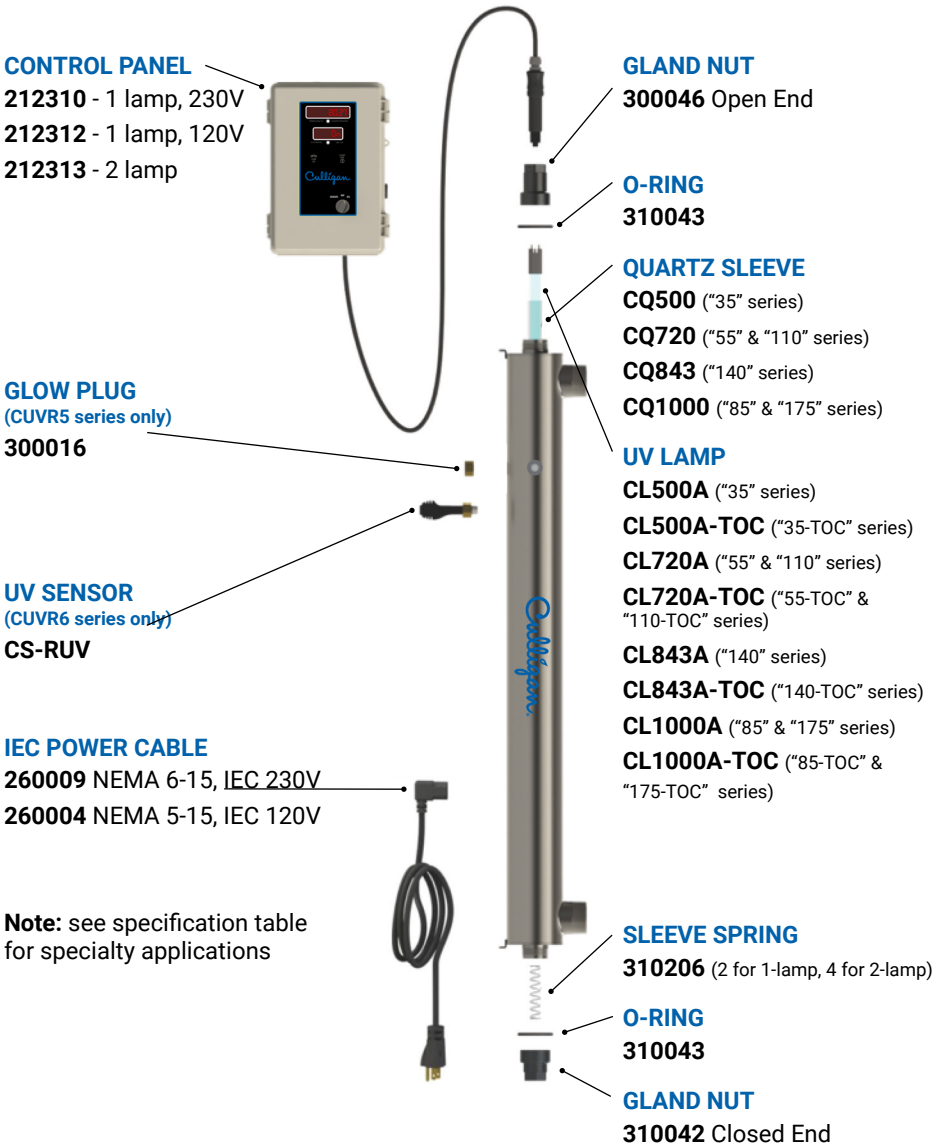

Figure 1. Culligan Commercial System Components

# System Sizing

All CULLIGAN UV systems are rated for a specific flow rate in water that meets the quality parameters. **PLEASE NOTE:** increasing the flow above this rating or disinfecting water that does not meet the quality parameters will decrease the dose and therefore compromise the efficacy of the system.

If you need to determine your maximum flow rate, you can fill a 1 gallon bucket with water and time how long it takes to fill up. It is always better to oversize your system than to undersize. For example, if your pump delivers 40GPM, it is recommended to install a CULLIGAN 58 GPM system.

# Installation Location

Find a suitable location to mount the UV reactor and the accompanying control panel. In choosing your location ensure that the panel is located within 5 feet of a ground fault circuit interrupter (GFCI) and that there is easy access to the main cold water line prior to any branch lines and before the hot water heater. If you have any other water treatment equipment, such as a softener or water filter, ensure that the UV is the last piece of treatment equipment. **PLEASE NOTE:** All CULLIGAN UV disinfection systems are intended for indoor use only as they should not be exposed to the elements.

There are two different sizes of CULLIGAN commercial control panels, depending on which system is purchased. See Figure 2 below for 1-lamp systems, Figure 3 for 2-lamp systems.

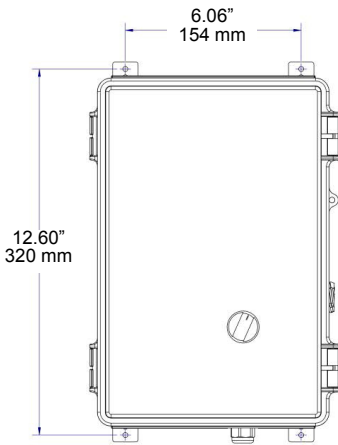

Figure 2. 1-Lamp Systems

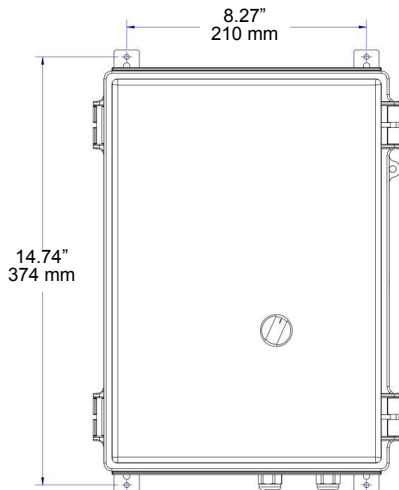

Figure 3. 2-Lamp Systems

To facilitate lamp removal, ensure there is enough space on the end with the open gland nut to safely remove the UV lamp and/or quartz sleeve (a space equal to the length of the unit will suffice) (see Figure 4).

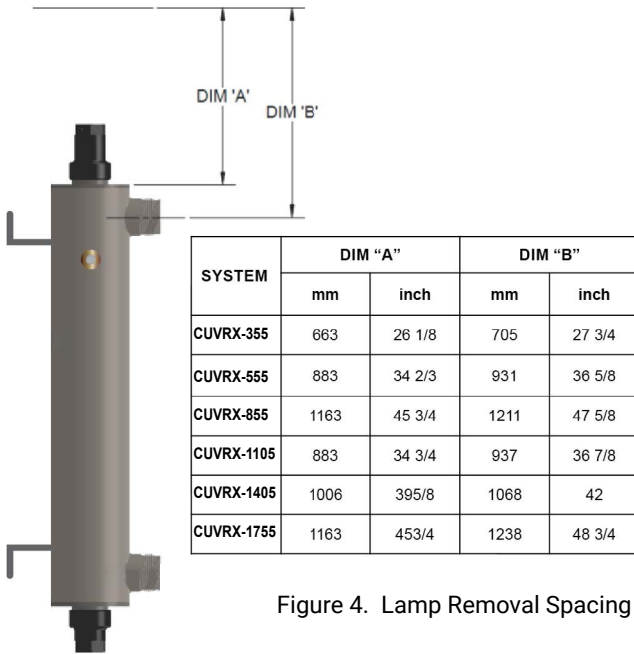

Figure 4. Lamp Removal Spacing

**PLEASE NOTE: ALL CULLIGAN UV DISINFECTION SYSTEMS ARE INTENDED FOR INDOOR USE ONLY AS THEY SHOULD NOT BE EXPOSED TO THE ELEMENTS.**

## Considerations Before Installation

- The UV disinfection system should always be the last piece of treatment before the water branches off to any hot or cold water lines.
- CULLIGAN strongly recommends that a 5 micron filter be installed before the UV system for a final polishing step before the water is disinfected.
- The reactor can be installed either horizontally or vertically.
- If you do not know the flow rate of the water supply in the application, it is recommended that you use a flow restrictor so that the rated flow of your particular CULLIGAN system is not exceeded and the UV dose is not compromised. The flow restrictor should be installed on the outlet port of the reactor.



- It is strongly recommended to have a licensed plumber connect the UV reactor to the water supply and may be a requirement depending on where you are located. If you are attempting this yourself, ensure you have all the necessary tools and fittings to accomplish this task.
- Although there are many methods of installation, this manual will provide a recommended procedure using copper plumbing and standard soldering methods. CULLIGAN recommends the use of unions, a bypass assembly and shut-off valves as this will allow you to isolate and remove the UV reactor if necessary (this is a recommended method only as it allows for the maximum convenience but it requires extra components and more time for installation).

## Installation

**Step 1:** Before you cut into the cold water line, measure and cut all piping as per the recommended layout. Once all the components are ready, start by installing the female adapters onto the ports of the reactor. To ensure a proper seal, the use of Teflon™ tape is recommended on all threaded connections.

**Step 2:** Solder whole assembly together; including ball valves and unions. Connect the bypass assembly to the cold water feed line (water in and water out).

**Step 3:** \*\*Skip this step if the system arrived with the quartz sleeve(s) installed.\*\* Once the system has been plumbed in, gently remove the quartz sleeve from its packaging using cotton gloves. Carefully slide the sleeve into the reactor, ensuring that it is centered, until it is all the way through the reactor and the amount of sleeve is even on both sides. Slide one O-ring onto each side of the sleeve, until they are butted up against the reactor. Repeat this step for the second sleeve on a 2-lamp system.

**Step 4:** Install the UV sensor (if applicable). Align the flat portion so it faces the gland nut end and matches up with the half metal lip on the sensor port (see Figure 6). Insert the sensor so it is fully seated and hand tighten the sensor nut. Plug the male connector into the sensor port located on the bottom of the control panel, (see Figure 7)

**Step 5:** Hand tighten the provided gland nuts over the quartz sleeve(s) onto the threaded end(s) of the reactor. They have a positive stop to prevent over-tightening. A firm force may be required to fully tighten the gland nuts, but DO NOT USE TOOLS for this step. Insert the provided stainless steel compression springs into the quartz sleeves. The spring works with the lamp and LUMI-Loc™ connector to create the proper lamp alignment. PLEASE NOTE: DO NOT install a UV lamp inside the quartz sleeve without the sleeve spring in place.



Figure 5. Quartz Sleeve Installation

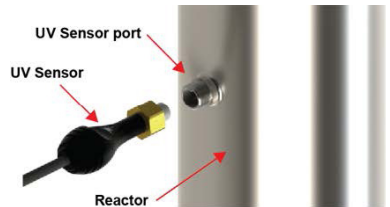

Figure 6. UV Sensor Installation

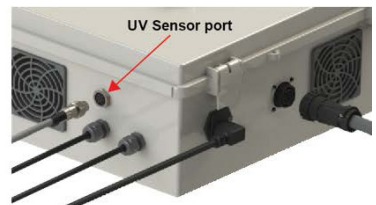

Figure 7. Sensor Connection

**Step 5:** The reactor is now ready for water flow. When all plumbing connections have been completed you should check for any possible leaks. Slowly turn on the water supply and check for leaks. Make sure that any bypass valves are functioning properly and that the water is flowing through the reactor. The most common leak is from the o-rings not making a proper seal on the reactor. If this is the case turn the water off, drain the reactor, remove each o-ring, dry them and reapply silicon grease. Replace each o-ring ensuring they are properly sealed against the reactor, re-tighten the gland nuts and check again for leaks.

**Step 6:** Mount the control panel to the wall so it is above or beside the reactor, to ensure that no moisture can deposit on any of the connections. The control panel can be mounted up to 8 feet away from the reactor.

**Step 7:** Using cotton gloves, remove the lamp from its packaging, making sure to only touch the ceramic ends of the lamp. Insert the UV lamp into the reactor, being careful not to drop it. Repeat this step for a 2-lamp system.

**Step 8:** Plug the LUMI-Loc™ lamp connector into the lamp, being careful to not crack the ceramic. Note the keying for proper alignment (see Figure 8). Insert the lamp connector into the gland nut and turn the connector approximately 1/4 turn to lock the connector to the gland nut (see Figure 9)

**\*Note:** Repeat Steps 7 & 8 for 2-lamp system.



Figure 8.  
UV Lamp  
Connection



Figure 9.  
LUMI-Loc™  
Connector

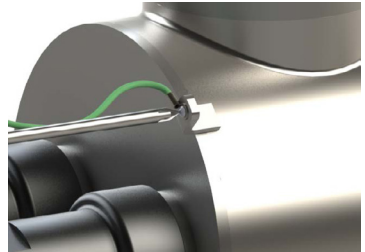

Figure 10. Ground Screw  
Connection

**Step 9:** Affix the ground wire to the ground lug on the UV reactor to ensure proper grounding continuity (see Figure 10).

**Step 10:** Your system is now ready to be plugged into the appropriate GFCI protected outlet. Refer to the following section before any water is allowed to flow through the system.

**Step 11:** Affix “Danger: Hot” label to the reactor.

# Care & Maintenance

## System Disinfection

With a new installation, or any time the UV system is shut down for service, without power, or is inoperative for any other reason, the lines in the home or facility could be contaminated. Use the following steps to fully disinfect the lines throughout the entire facility.

**Step 1:** Check for and remove any “dead ends” in the lines throughout the home as these can harbor bacteria. Plug in the UV system and wait until it is ready for operation.

**Step 2:** Remove the filter cartridge from the last sump and fill it with 1-2 cups of household bleach (most are 5.25% chlorine). Replace the sump and slowly turn on the water supply.

**Step 3:** At a water outlet, run the water until bleach can be smelled. Repeat this for all faucets, toilets, shower heads, refrigerators, outdoor taps, the washing machine, dishwasher, etc. at the home or facility. Once finished, wait a minimum of 30 minutes before continuing.

**Step 4:** Reinstall the filter cartridge into the sump and flush the chlorine solution by opening all faucets until chlorine can no longer be detected. Your home has now been completely disinfected and your UV system is ready to use.

## Cleaning the Quartz Sleeve

Depending on the water quality, the quartz sleeve may require periodic cleaning. At a minimum, the quartz sleeve should be cleaned on an annual basis. The following steps outline a basic cleaning procedure.

**Step 1:** If a bypass assembly is installed, shut the inlet valve off to prevent water flow through the system. Otherwise, turn off main water inlet valve (and/or turn off the water pump).

**Step 2:** Disconnect power cord of UV system from electrical outlet.

**Step 3:** Release water pressure by opening a downstream faucet and then close the outlet shut-off valve (if any). If there is no outlet shut-off valve, expect water to drain from the system as the head pressure in the system will cause the water to flow back down.

**Step 4:** Remove the captive ground screw from the ground lug on the UV reactor.

**Step 5:** Remove the lamp connector(s) from the reactor (gland nut) by pushing the LUMI-Loc™ connector in and turning it ¼ turn counter-clockwise. Disconnect the lamp connector(s) from the lamp(s). **CAUTION: the lamp(s) may be hot!**

**Step 6:** Being careful to touch only the ceramic ends, remove the lamp from the reactor.

**Step 7:** Unscrew the gland nuts from the reactor, exposing the ends of the quartz sleeve(s).

**Step 8:** While holding on to both ends of the sleeve carefully remove the o-ring from the end opposite from the lamp connection and then pull the quartz sleeve out of the reactor (ensure that no water enters the inside of the quartz sleeve); remove second o-ring

**Step 9:** Using a soft, lint-free cloth or towel, wipe the sleeve down using a commercial scale cleaner (i.e. CLR® or LIME-A-WAY®). This removes scaling or iron deposits that may be on the outside of the quartz sleeve. Be careful not to get any moisture or liquids inside of the sleeve.

**Step 10:** Dry the sleeve with separate cloth.

**Step 11:** Place the sleeve(s) back into the reactor following step 4 from installation section.

### **Cleaning the UV Sensor**

Depending on the water quality, the UV sensor may require periodic cleaning. At a minimum, the UV sensor should be cleaned on an annual basis. The following steps outline a basic cleaning procedure.

**Step 1:** If a bypass assembly is installed, shut the inlet valve off to prevent water flow through the system. Otherwise, turn off the main water inlet valve (and/or turn off the water pump).

**Step 2:** Disconnect power cord of UV system from electrical outlet.

**Step 3:** Release water pressure by opening a downstream faucet and then close the outlet shut-off valve (if any). If there is no outlet shut-off valve, expect water to drain from the system as the head pressure in the system will cause the water to flow back down.

**Step 4:** Place something under the reactor to catch any water that may come out of the reactor during the removal of the UV sensor.

**Step 5:** Unscrew (counterclockwise) sensor nut from the reactor and pull the sensor slowly out of the sensor port.

**Step 6:** Holding the sensor in your hand, wipe the flat portion (sensor face) of the sensor with isopropyl alcohol using a clean, lint-free cloth.

**Step 7:** Replace sensor following step 5 from the installation section of the manual.

**CAUTION: PRIOR TO PERFORMING ANY MAINTENANCE ON YOUR UV SYSTEM, YOU MUST ALWAYS DISCONNECT THE POWER (DO NOT SIMPLY USE THE SWITCH ON THE FRONT OF THE CONTROL PANEL).**



## Operation

The CULLIGAN commercial system comes with a feature laden control system that incorporates both the lamp driver (ballast) and control features in one modular panel. The LED display indicates remaining lamp life and total running hours, and has audible and visual warnings for lamp failure. With the remote monitoring cable, the controller supports a remote-on function, a 4-20mA status output and system ready, system fault dry contacts making it solenoid ready.

### 3-Position Switch

The control panel features a 3-position user-selectable switch. This switch is NOT a power switch and it should be noted that once the control panel is plugged into an electrical outlet, the unit is powered and considered "ON". The switch functions as follows:

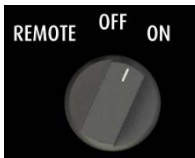

#### "ON" position

Power is supplied to the lamp(s) and the control panel will read "ON" on the lower LED display on units without a UV sensor installed and will read the intensity (or UV output) on units with a UV sensor installed.



#### "OFF" position

Power is NOT supplied to the lamp(s) and the lamp(s) will be off. The control panel will read "OFF" on the lower LED display.

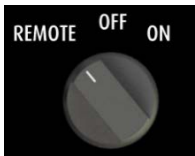

#### "REMOTE" position

In this position, the control of the unit is placed in a remote location (i.e. a computer) via an attached remote monitoring cable (order PN 210010). Through this cable, the operator must supply a 24 volt power source that will allow these "dry contacts" to operate. The screens and the "ON" and "OFF" functions will now all be operated remotely. While the UV control panel is in the remote position, **EXTREME CAUTION** must be exercised around the UV reactor while servicing the UV lamps as they may be turned on or off remotely without the operators knowledge or control.



## Power-up Sequence

Upon start up, the bottom LED on your control panel will countdown from 180 seconds as the system powers on. Once the countdown is finished, the UV system is ready for disinfection.



## UV Output (CULLIGAN RAINIER 6.0)

If your system is equipped with a UV sensor, your control panel will display the UV output in “% UV Intensity” or “mW/cm<sup>2</sup>”. The default output is “% UV Intensity” and to toggle between these two outputs, simply press the button located directly beneath the bottom LED screen. The LED screen will indicate the level of UV intensity that is being detected within the reactor by the sensor. Things that can affect the UV Output negatively are poor water quality, scaling of the quartz sleeve and/or sensor, lamp failure, expired lamp life and sensor failure.



When the UV output drops to ~60%, the system will display a “LOW UV” warning light in yellow and the system will emit an intermittent audible chirp. When the UV output drops to ~50% the system will display a “LOW UV” warning light in red and the system will emit a constant audible alarm. Values below 50% may be unsafe for consumption. Additionally, at this point, the control panel also provides a signal to de-activate the flow of water if implemented in the system. When the system registers a low UV condition, the only way to silence the alarms is to correct the reason for this low UV condition.

If the LED reads “OFF” then the water from the system may be unsafe for consumption. If any water does pass through the UV system during this period, please follow the disinfection procedure as outlined in this manual before the water is consumed.

The CUVR5 system does not measure the level of disinfection; it simply measures the “ON-OFF” status of the lamp. Please have your water checked for microbiological contaminants on a regular basis.

### Major Alarm Set Points:

System No. of Lamps	SYSTEM	Intensity (mW/cm <sup>2</sup> )	UVT(%)
1	Regular, TOC, HW	17	50
1	Low UVT	13	50
2	Regular, TOC, HW	15	50
2	Low UVT	10	50

### Minor Alarm Set Points

System No. of Lamps	SYSTEM	Intensity (mW/cm <sup>2</sup> )	UVT(%)
1	Regular, TOC, HW	20.3	58
1	Low UVT	15.6	60
2	Regular, TOC, HW	18	60
2	Low UVT	12	60

### Lamp Countdown Sequence

The control panel displays a countdown feature that displays the number of hours remaining until a lamp change is required. At 512 hours until lamp change the numerical lamp change value will begin to flash indicating that lamp expiration is near. At "zero hours remaining", the system registers an audible alarm. If you wish to silence this audible alarm, simply press and hold down the button located directly beneath the top LED screen for three seconds. **PLEASE NOTE:** During the condition of lamp expiration, the water may be unsafe for consumption and should not be consumed without another form of disinfection.



### Lamp Replacement

After the lamp is expired, it must be replaced with the same part number as indicated by the label on the reactor. Begin replacing the lamp by unplugging the power for the controller, then refer to Installation for instructions on installing the new lamp. After changing the lamp(s) the control panel must be reset in order for the system to begin its countdown function on the newly installed lamp(s). To reset, simply press and hold down the button located directly beneath the top LED screen for fifteen seconds. Release the button and then unplug & plug the system back in. The lamp countdown timer has now been reset.

**\*After lamps are expired, they must be replaced with the same part number as indicated on the label on the reactor (see steps 7 & 8 on page 8 for how to replace the lamps).**

# System Troubleshooting

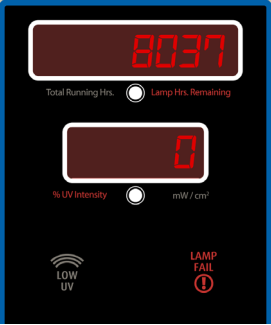
The control panel continuously monitors your UV system and if there is a problem with the system the panel will provide both a visual and audible signal indicating the specific fault that it is detecting. The fault conditions are listed in a priority sequence as follows:

System Display	Problem	Resolution
	<p>The system has detected a problem with the lamp.</p>	<p>Replace lamp If that does not resolve the alarm, replace ballast.</p>
	<p>The UV sensor is no longer communicating with the system.</p>	<ol style="list-style-type: none"> <li>1. Unplug controller from outlet and sensor from controller</li> <li>2. Plug sensor back in and restart system</li> <li>3. If FAIL is still displayed, replace sensor</li> </ol>



# Expansion Options

Although features such as remote-on, system ready and fault dry contacts, and 4-20 mA output are built into the control panel, they require an optional cable as below.



**Remote Monitoring Cable (for both 4-20mA and remote monitoring options)** Part # 210010  
Includes connector and 10m (33') of cable to provide both a 4-20 mA signal, dry contacts for system ready, fault signals and 24V DC remote-on input to a remote location.

Contact your authorized distributor for purchasing information.

## CULLIGAN, Light Commercial Amalgam UV systems, UV Monitored, UV Non-Monitored

Model	CUVR5/6-355 CUVR5/6-355-HW CUVR5/6-355-TOC	CUVR5/6-555 CUVR5/6-555-HW CUVR5/6-555-TOC	CUVR5/6-855 CUVR5/6-855-HW CUVR5/6-855-TOC	CUVR5/6-1105 CUVR5/6-1105-HW CUVR5/6-1105-TOC	CUVR5/6-1405 CUVR5/6-1405-HW CUVR5/6-1405-TOC	CUVR5/6-1755 CUVR5/6-1755-HW CUVR5/6-1755-TOC
Normal Flow Rate 30 mJ/cm <sup>2</sup> @ 95% UVT	35 GPM 132 lpm 8 m <sup>3</sup> /hr.	55 GPM 208 lpm 12.5 m <sup>3</sup> /hr.	85 GPM 322 lpm 19.3 m <sup>3</sup> /hr.	140 GPM 530 lpm 31.8 m <sup>3</sup> /hr.	180 GPM 681 lpm 40.9 m <sup>3</sup> /hr.	215 GPM 814 lpm 48.8 m <sup>3</sup> /hr.
Hot Water Flow Rate 30 mJ/cm <sup>2</sup> @ 75% UVT	22 GPM 83 lpm 5 m <sup>3</sup> /hr.	38 GPM 144 lpm 8.6 m <sup>3</sup> /hr.	60 GPM 227 lpm 13.6 m <sup>3</sup> /hr.	75 GPM 284 lpm 17.0 m <sup>3</sup> /hr.	95 GPM 360 lpm 21.6 m <sup>3</sup> /hr.	115 GPM 435 lpm 26.1 m <sup>3</sup> /hr.
LOW UVT Flow Rate 30 mJ/cm <sup>2</sup> @ 50% UVT	14 GPM 53 lpm 3.2 m <sup>3</sup> /hr.	23 GPM 87 lpm 5.2 m <sup>3</sup> /hr.	35 GPM 132 lpm 8 m <sup>3</sup> /hr.	39 GPM 148 lpm 8.9 m <sup>3</sup> /hr.	49 GPM 185 lpm 11.1 m <sup>3</sup> /hr.	60 GPM 227 lpm 13.6 m <sup>3</sup> /hr.
TOC Flow Rate 150 mJ/cm <sup>2</sup> @ 95% UVT	7 GPM 26 lpm 1.6 m <sup>3</sup> /hr.	12 GPM 45 lpm 2.7 m <sup>3</sup> /hr.	17 GPM 64 lpm 3.9 m <sup>3</sup> /hr.	31 GPM 117 lpm 7.0 m <sup>3</sup> /hr.	40 GPM 151 lpm 9.1 m <sup>3</sup> /hr.	48 GPM 182 lpm 10.9 m <sup>3</sup> /hr.
Alt. flow-US Public Health 16 mJ/cm <sup>2</sup> @ 95% UVT	66 GPM 250 lpm 15 m <sup>3</sup> /hr.	109 GPM 413 lpm 24.8 m <sup>3</sup> /hr.	167 GPM 632 lpm 37.9 m <sup>3</sup> /hr.	266 GPM 1007 lpm 60.4 m <sup>3</sup> /hr.	337 GPM 1276 lpm 76.5 m <sup>3</sup> /hr.	406 GPM 1537 lpm 92.2 m <sup>3</sup> /hr.
Alternate Flow 40 mJ/cm <sup>2</sup> @ 95% UVT	26 GPM 98 lpm 5.9 m <sup>3</sup> /hr.	44 GPM 167 lpm 10 m <sup>3</sup> /hr.	57 GPM 216 lpm 12.9 m <sup>3</sup> /hr.	106 GPM 401 lpm 24.1 m <sup>3</sup> /hr.	135 GPM 511 lpm 30.7 m <sup>3</sup> /hr.	163 GPM 617 lpm 37.0 m <sup>3</sup> /hr.
Port Size	1½" MNPT	2" MNPT	2" MNPT	2½" MNPT	3" MNPT	4" MNPT
Electrical	110V/60Hz. or 230V./50-60Hz. (IEC power cords required) (MUST specify voltage when ordering)					
Plug Type	European CEE 7/7, 3-wire for all 230V. - "2" suffix British Standard, BS1363, 3-wire for all 230V. - "3" suffix Australian AS/NZ 3112, 3-wire for all 230V. - "4" suffix North American IEC, 3 prong 110V. - "1" suffix. North American NEMA 6-15, 3 prong 230V. - "5" suffix					
Lamp Watts	104	152	207	304	344	414

Power (Watts)	120	170	220	320	360	430
Replacement Lamp (disinfection @ 254 nm)	CL500A (1 required)	CL720A (1 required)	CL1000A (1 required)	CL720A (2 required)	CL843A (2 required)	CL1000A (2 required)
Replacement Lamp (Hot Water @ 254 nm)	CL-500A (1 required)	CL720A (1 required)	CL1000A (1 required)	CL720A (2 required)	CL843A (2 required)	CL1000A (2 required)
Replacement Lamp (TOC @ 185 nm)	CL500A-TOC (1 required)	CL720A-TOC (1 required)	CL1000A-TOC (1 required)	CL720A-TOC (2 required)	CL843A-TOC (2 required)	CL1000A-TOC (2 required)
Replacement Sleeve	CO500 (1 required)	CO720 (1 required)	CO1000 (1 required)	CO720 (2 required)	CO843 (2 required)	CO1000 (2 required)
Chamber Material	316L Stainless Steel, A249 Pressure Rated Tubing, Polished & Passivated					
Reactor Dimensions	4 x 27.2 x 7" (10 x 69 x 18 cm)	4 x 35.8 x 7" (10 x 91 x 18 cm)	4 x 46.9 x 7" (10 x 119 x 18 cm)	6 x 35.8 x 9.4" (15 x 91 x 24 cm)	6 x 40.7 x 9.4" (15 x 103 x 24 cm)	6 x 46.9 x 9.4" (15 x 119 x 24 cm)
Controller Dimensions	12 x 8.4 x 7" (30 x 21 x 18cm)					
Maximum Operating Pressure	10.3 bar (150 psi)					
Operating Temperature Range	2-60° C (36-148° F)					
UV Monitoring Port (Upgradeability)	YES					
Remote - On	YES					
Dry Contacts (Solenoid Ready)	YES (requires optional <b>210010</b> cable assembly sold separately)					
4-20 mA Output	OPTIONAL (requires optional UV sensor ( <b>CS-RUV</b> ) and cable assembly ( <b>210010</b> ), sold separately)					
Lamp Age Counter	YES					
Visual Lamp-Out Indicator	YES					
Audible Lamp-Out Alarm	YES					
Shipping Weight	Call Factory	Call Factory	Call Factory	Call Factory	Call Factory	Call Factory

## **Culligan Systems Limited Warranty Statement**

Products manufactured for Culligan by LUMINOR Environmental Inc. (LUMINOR) are warranted to the original user only to be free of defects in material and workmanship for a period as specified below. This warranty only applies to the original purchaser and is not transferable.

### **UV SYSTEMS**

Ten (10) year Limited Warranty on the stainless steel reactors, from the date of original purchase, or installation (proper documentation required for verification).

### **ELECTRONICS**

Three (3) year Limited Warranty on the ballasts and controllers, from the date of original purchase, or installation (proper documentation required for verification).

### **UV LAMPS, UV SENSORS & QUARTZ SLEEVES**

One (1) year Limited Warranty on all Culligan ultraviolet lamps, UV sensors and quartz sleeves from the date of original purchase, or installation (proper documentation required for verification).

LUMINOR warrants that it will repair, replace or refund, at LUMINOR's sole option, any ultraviolet system or component that is defective in materials or workmanship for the period as outlined above, subject to the "Limitations of Warranty" as outlined below. LUMINOR's liability under this warranty shall be limited to repairing or replacing at LUMINOR's option, without charge, F.O.B. LUMINOR's factory or authorized service depot, any product that LUMINOR manufactures. LUMINOR will not be liable for any costs of removal, installation, transportation, or any other charges which may arise in connection with a warranty claim. Products which are sold but not manufactured by LUMINOR are subject to the warranty provided by the manufacturer of said products and not by LUMINOR's warranty. LUMINOR will not be liable for damage or wear to products caused by abnormal operating conditions, accident, abuse, misuse, unauthorised alteration or repair, or if the product was not installed in accordance with LUMINOR's printed installation and operating instructions.

### **LIMITATIONS OF WARRANTY**

This warranty does not apply to any of the following:

- Water Quality Parameters lie outside of the following ranges
  - Hardness > 120 mg/L (7 gpg)
  - Iron > 0.3 mg/L (ppm)
  - Manganese > 0.05 mg/L (ppm)
  - Tannins > 0.1 mg/L (ppm)
  - Turbidity > 1 NTU
  - Transmittance (UVT) < 75%
- A product that has been incorrectly installed according to the technical installation manual.
- A product that has been modified in any manner, unless approved by the manufacturer.
- A product where the serial number has been altered defaced or removed.
- Damage caused by the use of parts that are not compatible, suitable and/or authorised by Culligan for use with the product (e.g. non-original lamps or sleeves).
- Damage caused during shipment of the product.
- Water damage is found inside ballast housing or controllers.
- Product is installed outdoors in direct contact with the environment (rain).
- Product is installed in freezing temperatures.
- Product is used in conditions that exceed Culligan's specifications.

## TO GET WARRANTY SERVICE

To obtain service under this warranty, you must first contact LUMINOR Customer Service at (855) 837-3801 to obtain a Warranty Return Authorization. You will then need to return the product through the Culligan Dealer or Distributor where the product was originally purchased, together with proof of purchase and installation date, failure date, and supporting installation data. Unless otherwise provided, the Dealer or Distributor will contact LUMINOR for instructions on returning the product. Any defective product to be returned to LUMINOR must be sent freight prepaid; documentation supporting the warranty claim and/or a Return Material Authorization must be included if so instructed.

LUMINOR WILL NOT BE LIABLE FOR ANY INCIDENTAL OR CONSEQUENTIAL DAMAGES, LOSSES, OR EXPENSES ARISING FROM INSTALLATION, USE, OR ANY OTHER CAUSES. THERE ARE NO EXPRESS OR IMPLIED WARRANTIES, INCLUDING MERCHANTABILITY OR FITNESS FOR A PARTICULAR PURPOSE, WHICH EXTEND BEYOND THOSE WARRANTIES DESCRIBED OR REFERRED TO ABOVE. THIS LIMITED WARRANTY IS THE SOLE AND EXCLUSIVE WARRANTY MADE BY LUMINOR WITH RESPECT TO THE PRODUCT, AND IS GIVEN IN LIEU OF ANY OTHER WARRANTY. TO THE EXTENT ALLOWED BY APPLICABLE LAW, ANY AND ALL EXPRESS OR IMPLIED WARRANTIES NOT SET FORTH HEREIN ARE WAIVED AND DISCLAIMED, INCLUDING ANY IMPLIED WARRANTY OF MERCHANTABILITY OR FITNESS FOR A PARTICULAR USE. LUMINOR LIABILITY UNDER THIS LIMITED WARRANTY IS LIMITED SOLELY TO THOSE LIABILITIES SET FORTH ABOVE. IN THE EVENT THAT ANY PROVISION OF THIS LIMITED WARRANTY SHOULD BE OR BECOME INVALID OR UNENFORCEABLE UNDER APPLICABLE LAW, THE REMAINING TERMS AND CONDITIONS HEREOF SHALL REMAIN IN FULL FORCE AND EFFECT AND SUCH INVALID OR UNENFORCEABLE PROVISION SHALL BE CONSTRUED IN SUCH A MANNER AS TO BE VALID AND ENFORCEABLE.

## Warranty Registration

It is imperative that you complete the warranty registration process. This not only registers your UV disinfection system for the provided manufacturer's warranty, but also allows the factory to provide you with any important product updates or technical bulletins concerning your product. The registration process is a simple process and can ONLY be done online at **[www.uv-warranty.com](http://www.uv-warranty.com)**. Please ensure that ALL information is filled in, including a valid e-mail address. **PLEASE NOTE:** This information is for the sole purpose of technical support for your disinfection system and will not be used, or sold, to any other organisation for any other purpose.







Manufactured under licence by:

**LUMINOR Environmental Inc.**

80 Southgate Drive, Unit 4

Guelph, Ontario N1G 4P5

Phone (855) 837-3801

[www.luminoruv.com](http://www.luminoruv.com)

**better water. pure and simple.®**



EPA Establishment  
#088776-CAN-001

PN: 919370  
RevA / 04-24